



DEKBOARD[®]

Aluminium Subframe Installation Guide

Designed to assist the trade professional
with the installation of the DekBoard
Aluminium Subframe System

Index & Introduction

Aluminium Subframe System Benefits	2	Securing the Front of Step Subframes	16
Parts & Terminology	3	Inbound Posts for Steps	17
Parts & Key Dimensions	4	Step Fascia Preparation	18
Ring Beam Construction	6	Step Fascia Fixing	19
Joist Installation	7	Fascia Finishing Trims	20
Noggin Installation	8	Fixing Deck Planks to Steps	21
Corner Bracket to Post Installation	9	Post Light Fixing	22
Fascia Installation	10	Gate Hanging	24
Deck Plank Installation	11	Fixing Summary	25
Step Installation	12	Technical Information	26
Creating Ring Beams for Steps	13	Product Guarantee	27
Fixing Step Subframes to Posts	14		

Aluminium Subframe System

The introduction of the DekBoard aluminium subframe system, in conjunction with our PVC-U decking & balustrade, offers a premium subframe solution.

It's primarily aimed at install locations with flooding challenges, decking protruding into wet areas, or where the customer simply requires a strong, maintenance-free decking system with maximum longevity.

Designed in-house, the aluminium frame can replace all timber elements of a traditional subframe and supporting structure.

Benefits of Aluminium Subframes

- Aluminium is a sustainable material, that can be recycled and used time and again, offering long-term benefits without compromising on environmental responsibility.
- Aluminium subframes have a lighter load weight than timber frames, making them easier to handle and more fuel efficient during transportation.

- Unlike timber, aluminium frames are impervious to moisture, insect, and fungal attack which greatly increases their lifespan. This makes them a great choice for decking installations near to, or in wet areas (eg flood plains or lakes etc) and for European climates.

Fire Rated

Untreated aluminium is non combustible and as such has a Euroclass A rating. When combined with DekBoard's PVC-U decking the system has a Bfl-s1 fire performance.

Strong and Lightweight

DekBoard aluminium subframes are strong and lightweight. Their design load is based on BS EN 1991-1-1-2002 (Areas for domestic and residential activities - Balconies in single family dwellings).

Using DekBoard PVC-U profiles in combination with our aluminium subframes will produce a deck that is built to last.

Parts & Terminology

DekBoard Aluminium Subframe System

The DekBoard Aluminium Subframe system is sold as a complete system and as such all parts should be sourced from DekBoard to validate guarantees.

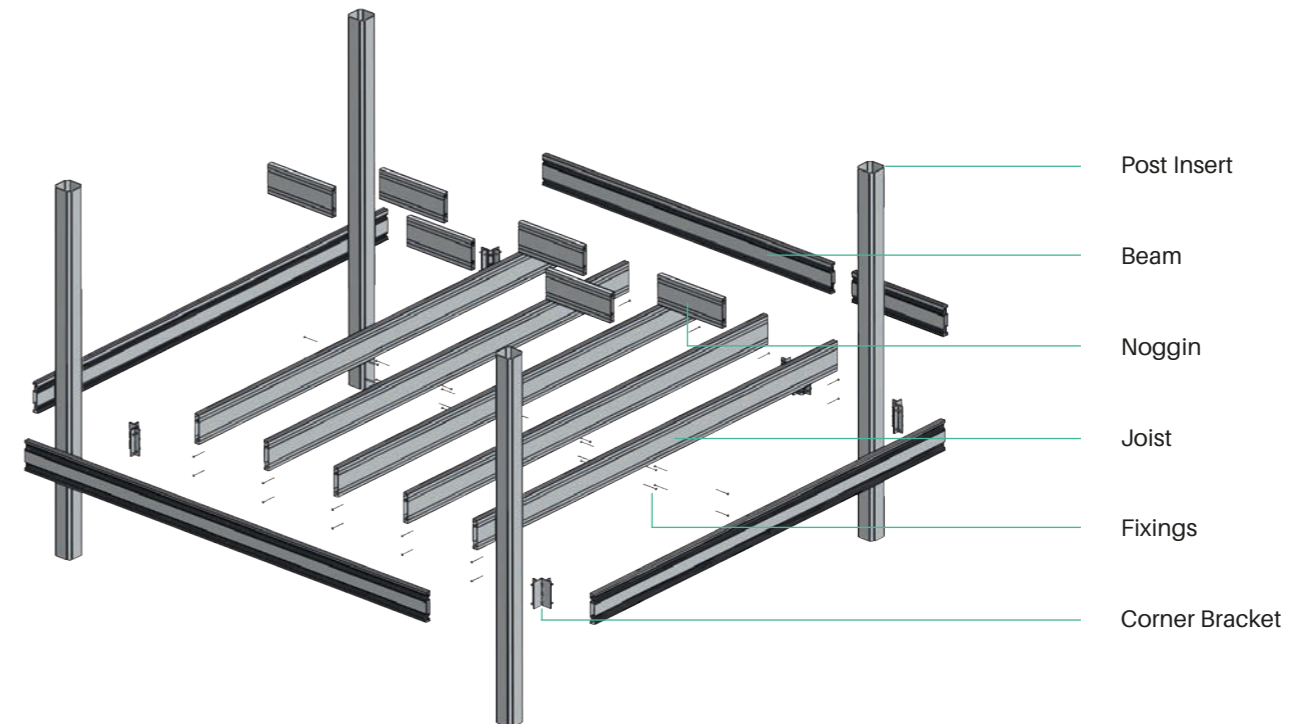

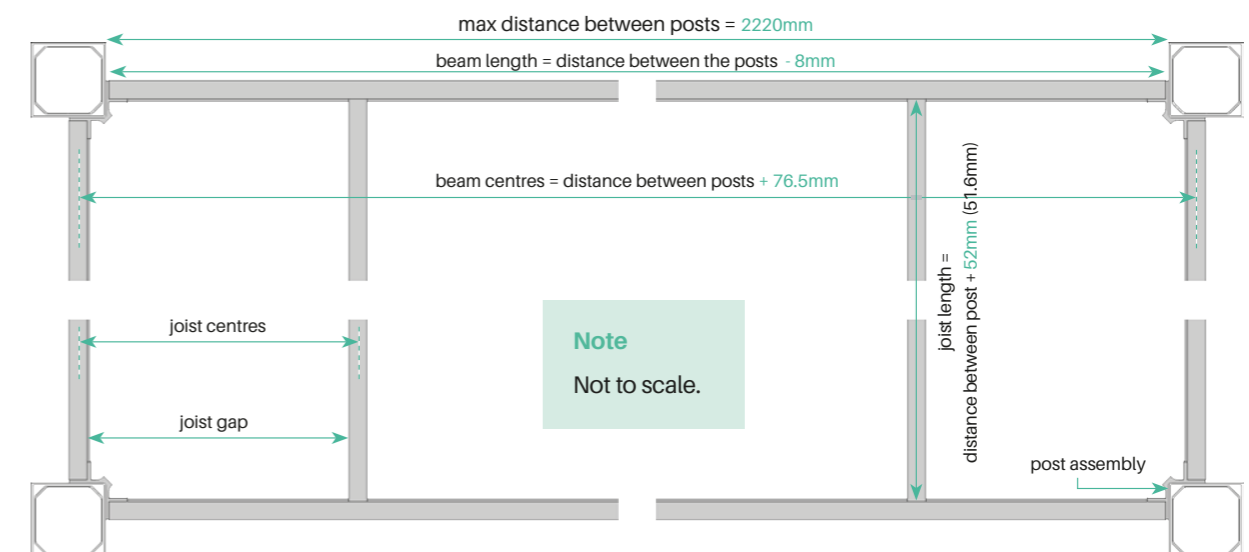

Terminology and Key Dimensions

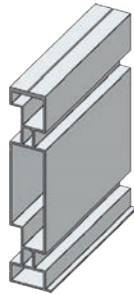
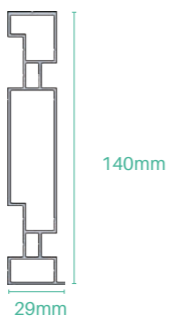
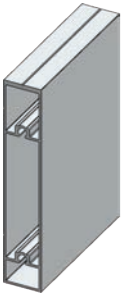
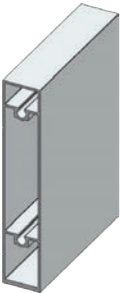
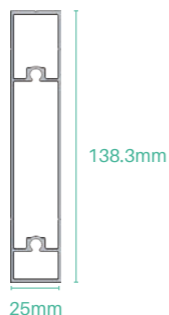
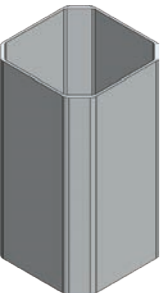
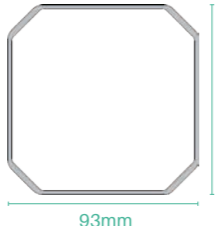

Terminology	Description
Subframe	The complete structure onto which the decking planks are secured
Subframe Module	Ring beam, Joist / Noggin assembly secured together to form the subframe
Ring Beam	The beam and corner bracket assembly
Joist Centres	The distance between joists measured at the joist centre line.
Post Assembly	PVC-U Post Sleeve with full height Post Insert

Parts & Key Dimensions

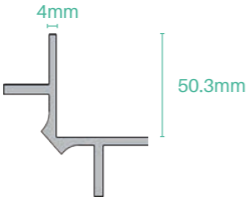
Subframe and Accessories		Code	Description
		DALBEAM	Beam
 		DALJOIST	Joist / Noggin † † Rotate Joist profile 180° for Noggin
		DALPOST	Post Insert
		DALCNRBKT	Corner Bracket

*ALL dimensions are nominal values only

Ring Beam Preparation

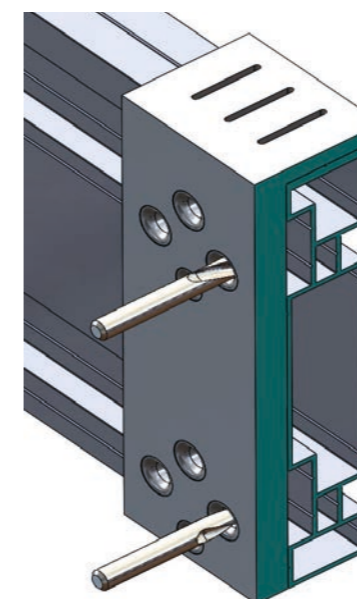

Pre-Drilling Ring Beams

Drill 2 x 7mm clearance holes at each end of the beam using the drill jig provided, ensuring the highlighted faces are flush to provide a 12.5mm distance from the end of the beam.

Beam Fixing	Fixings
Pre-Drilled Holes	2 x 7mm holes, 12.5mm from the beam end
Beam to corner bracket	2 x M6 x 25mm stainless steel socket head cap screws



DABEAMSCREW25 Fixing

TIP

To prevent movement when drilling, use a quick release clamp to hold the jig in place.

Note

Make sure the beam lip is positioned to the bottom inside edge to provide support for the joists / noggins.

Fit Corner Brackets

Connect the corner brackets to produce a ring beam using M6 stainless steel socket head cap screws ensuring the bracket is sat on the ring beam lip on the inside inner face.

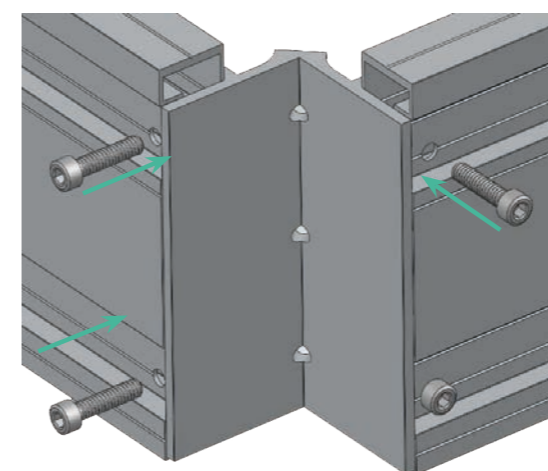

Fix using socket head cap screws

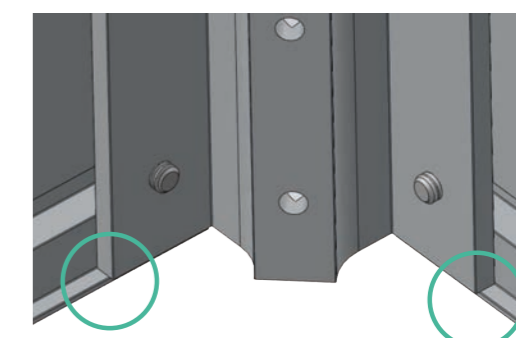

Ring beam lip on the inside inner face

IMPORTANT!

Do NOT use impact drivers to fix the screws.

Ring Beam Construction

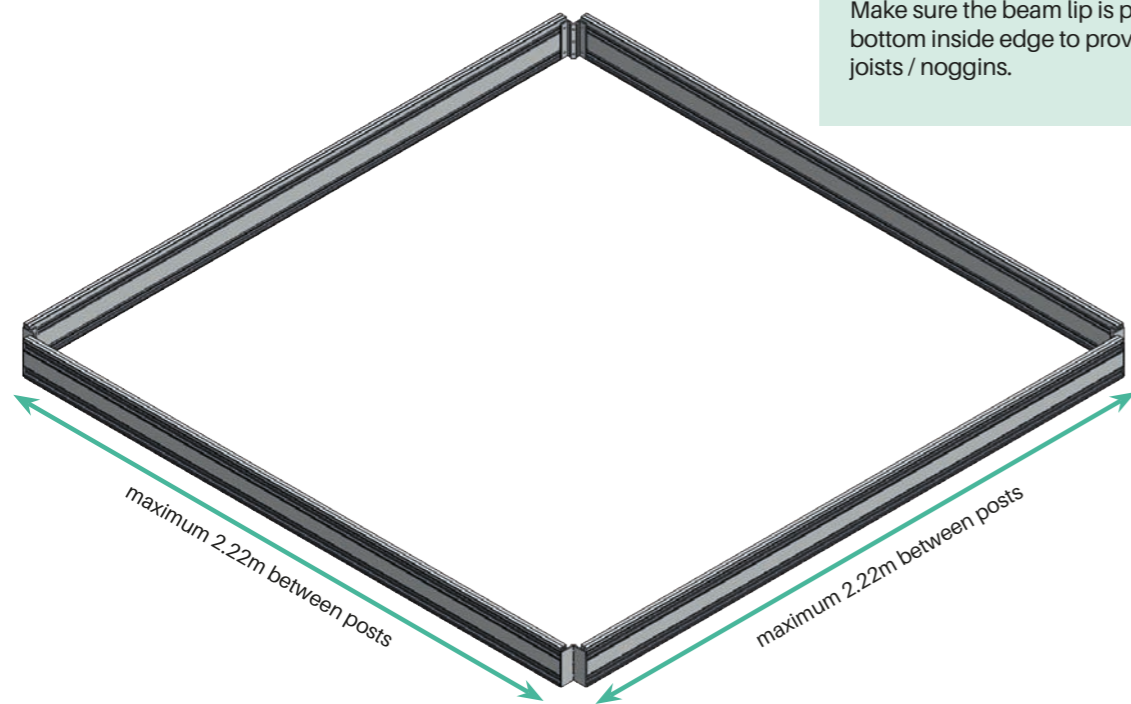

Note

Make sure the beam lip is positioned to the bottom inside edge to provide support for the joists / noggins.

Joist Positioning

Once all four beams are connected to the corner brackets, mark up joist centres on top of ring beams at maximum 400mm centres.

It is recommended joist centres are reduced to 300mm in areas of high foot traffic.

Drill 2 x 7mm clearance holes through beams using the drill jig provided.

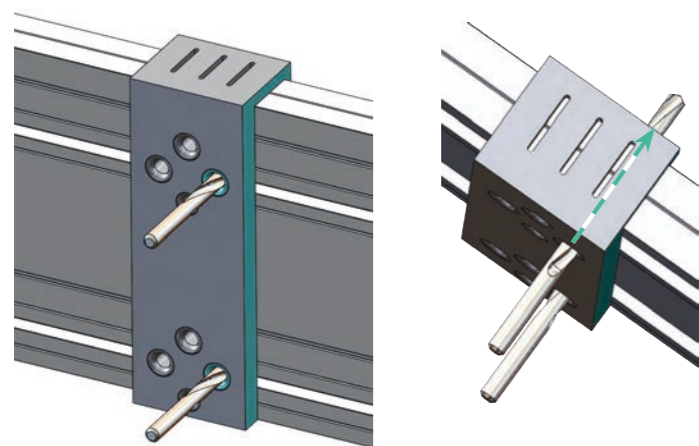

Note

Drill fully through the beam clearing any swarf from the hole edges.

TIP

To prevent movement when drilling, use a quick release clamp to hold the jig in place.

Joist Install	Fixing
Centres	max 400mm centres
Pre-drilled Holes	2 x 7mm pre-drilled holes through the beam at each joist centre mark

Joist Installation

Insert joists into position within the ring beam, sitting the joist on the lip at the bottom of the beam.

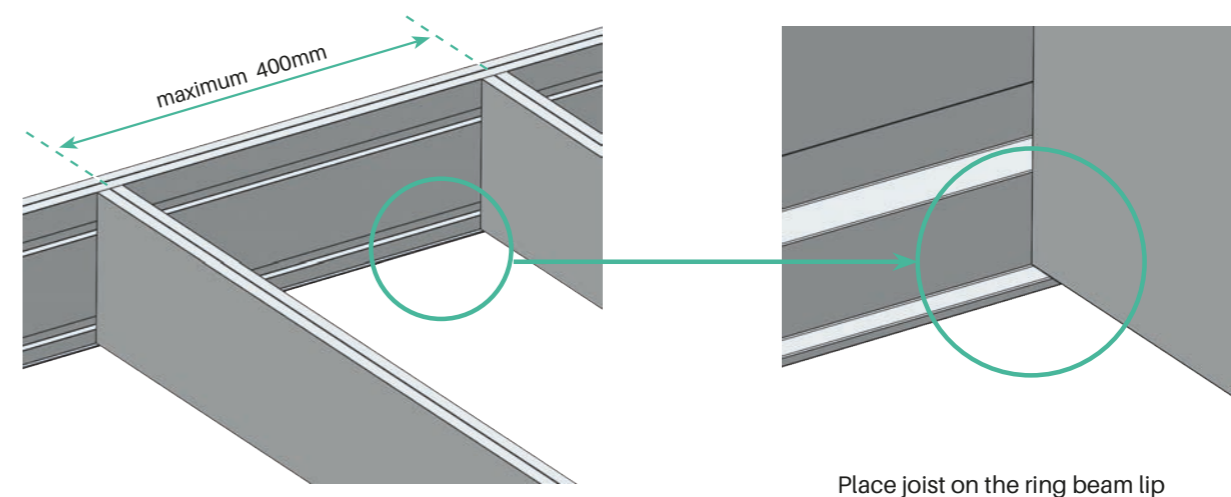

Secure joists into position with 2 x No.14 self-tapping 70mm Zinc coated Pan headed Torx screws (T30)

The self tapping screws should locate into the screw ports provided in the joist.

Joist Install	Fixing
Centres	max 400mm centres
Pre-drilled Holes	2 x 7mm pre-drilled holes through the beam at each joist centre mark
Fixing	2 x No.14 self-tapping 70mm zinc coated pan headed Torx screws (T30)



DAJOISTSCREW70 Fixing

IMPORTANT!

Do NOT use impact drivers to fix the screws.

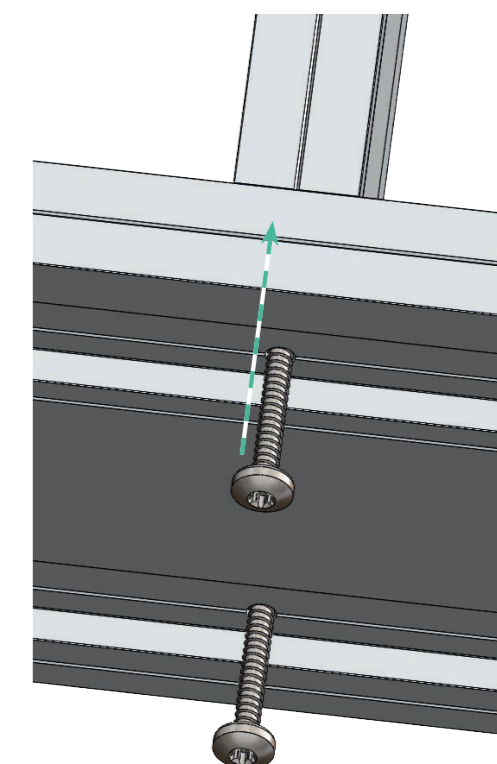

Fix joist to beam

Noggin Installation

Noggins

The subframe is designed to perform in-line with a timber subframe manufactured from C16 145mm x 47mm treated timber, at a maximum 2220mm distance between posts. Joist centres must not exceed 400mm for domestic load.

For greater rigidity noggins can be placed between joists using the joist profile turned upside down.

Using the drill jig, drill 2 x 7mm clearance holes at the points shown, into the joist and ring beam where required.

Fix the noggins with 2 x No.14 self-tapping 70mm Stainless Steel Panhead Torx screws per end (4 per noggin).

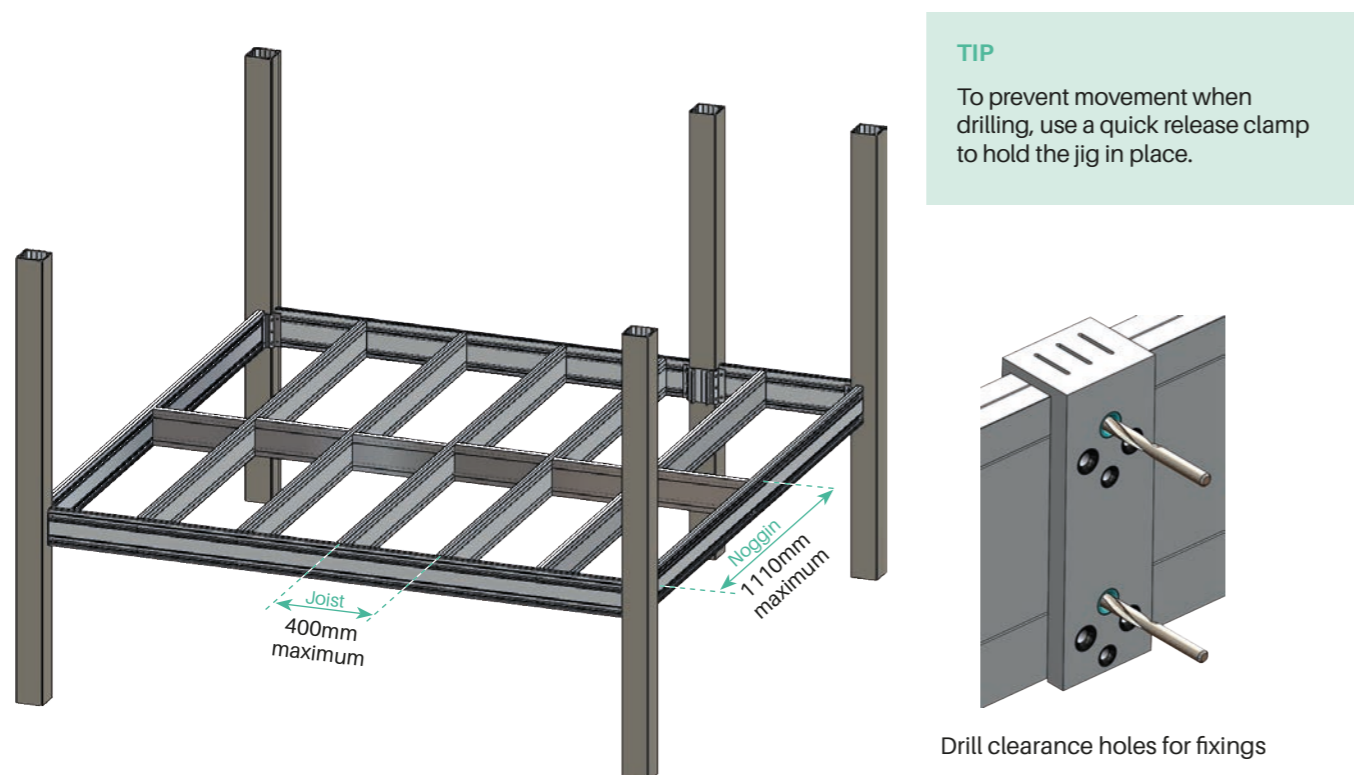

TIP
To prevent movement when drilling, use a quick release clamp to hold the jig in place.

Drill clearance holes for fixings

Noggin to Beam Install	Fixing
Pre-drilled Holes	2 x 7mm pre-drilled holes
Fixings	2 x No.14 self-tapping 70mm stainless steel panhead Torx screws per end (4 per noggin)
Fixing Centres	Maximum 1.11m



DANOGNSCREW70 Fixing

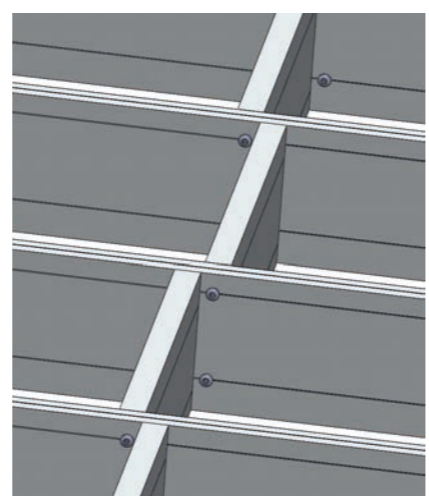

Noggins should be staggered to allow for fixings

IMPORTANT!
Do NOT use impact drivers to fix the screws.

Corner Bracket to Post Installation

Post Fixing

Once joists are secured, the subframe module can be positioned on axel stands to achieve the desired height.

When level, offer up the post assembly (post and PVC-U post sleeve), mark and cut to size.

Ensure the post assembly is vertical and square, then insert 3 x No.12 x 50mm stainless steel self-drilling Hex screws through the bracket into the post assembly.

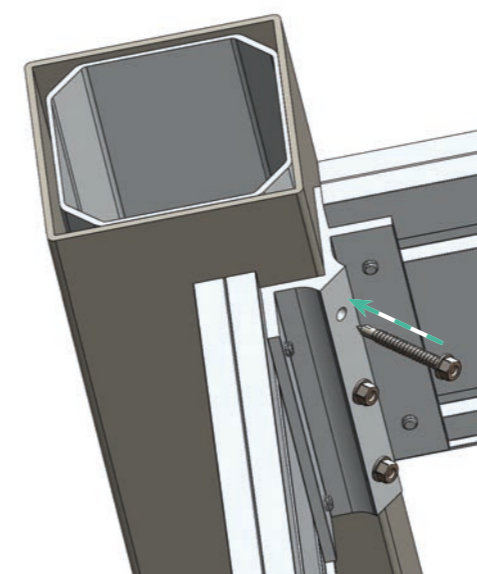

Note
It may prove to be easier to pilot drill holes through the PVC-U, with a 5.5mm drill bit, prior to inserting the screws.

Corner Bracket to Post Install	Fixing
Pilot Holes (through PVC-U)	3 x 5.5mm pre-drilled holes
Fixings (per Bracket)	3 x No.12 x 50mm stainless steel self-drilling Hex screws per bracket



DACBKTSREW50 Fixing

TIP
Take care not to damage caravan / lodge subframe / chassis.

Finding the subframe height

Identify the lowest door frame on the sides of the caravan adjacent to the deck.

From this point, measure 35mm down and mark as a datum point for the string line.

The top of the subframe should be aligned to this datum point.

Tying the deck to the underside of the caravan

Use a 150 x 50mm nominal wooden lath to attach the subframe to the underside of the caravan leaving a 94mm gap from the subframe inner face to caravan side.

Care to be taken not to block caravan / lodge ventilation paths.

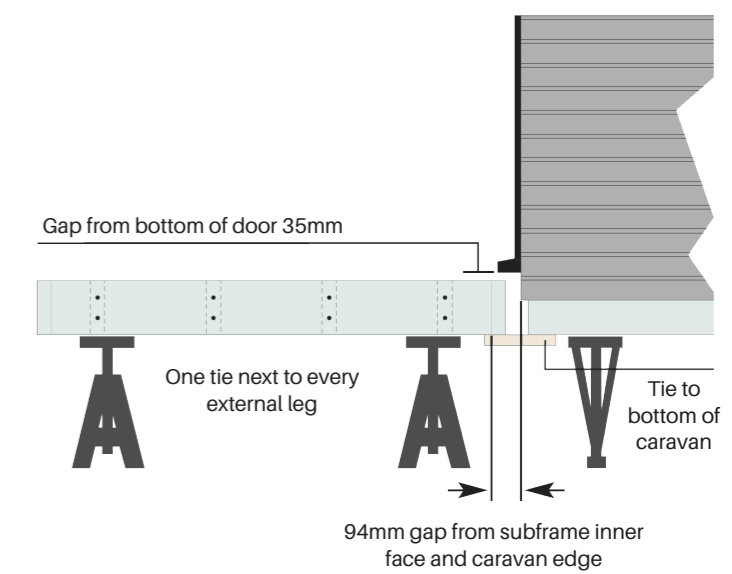

Fascia Installation

Fascia Fixing

Drill clearance holes using the drill jig at two points as shown using a 5.5mm drill bit. It is recommended to drill the beam from the outer face inwards.

Max fascia fixing centres 1200mm.

Fix fascia in place from inside face of beam using 2 x No.10 x 38mm self-tapping stainless steel pan head screws at each fixing centre.

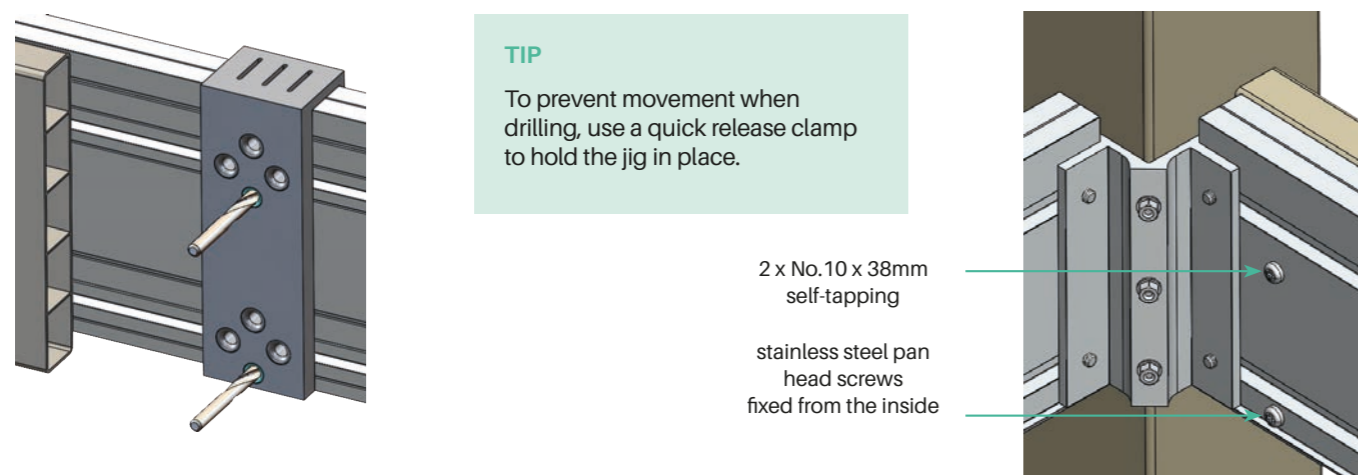

TIP
To prevent movement when drilling, use a quick release clamp to hold the jig in place.

2 x No.10 x 38mm self-tapping
stainless steel pan head screws fixed from the inside

Fascia to Beam Install	Fixing
Pre-drilled Holes	2 x 5.5mm pre-drilled holes (from the outside)
Fixings	2 x No.10 x 38mm self-tapping stainless steel pan head screws (from the inside)
Fixing Centres	Maximum 1200mm



DAFASCIASCREW38 Fixing

Mid Span Post

If a mid span post is required the ring beam can be cut and a post fitted by simply using 2 x corner brackets as shown below.

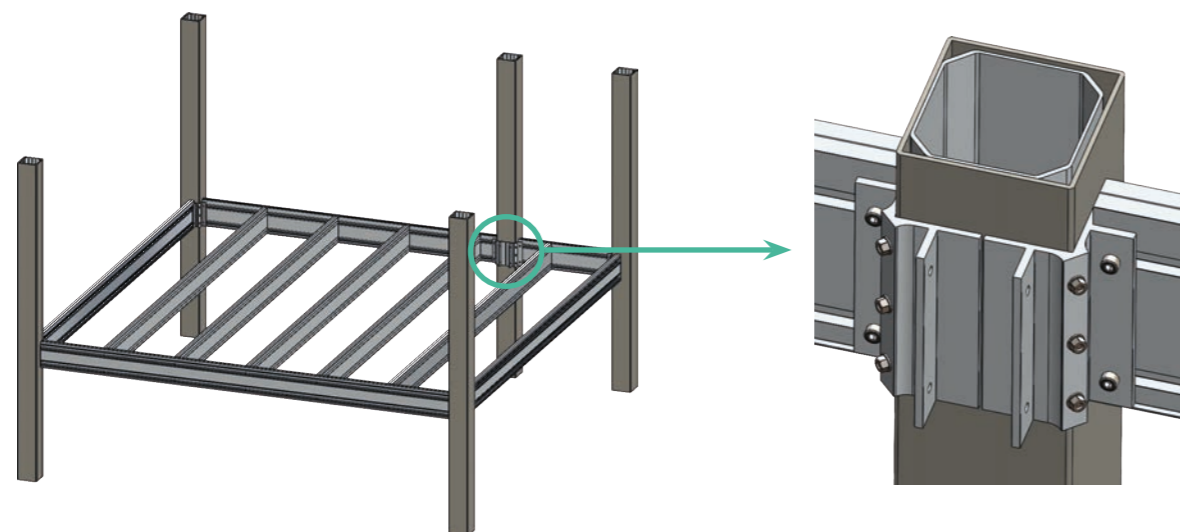

Deck Plank Installation

Decking Planks

Secure decking planks to the subframe using decking clips with No.8 x 16mm Pozi self drilling, stainless steel countersunk screws.

The joist profile has a screw guide line down the centre to aid with installation.

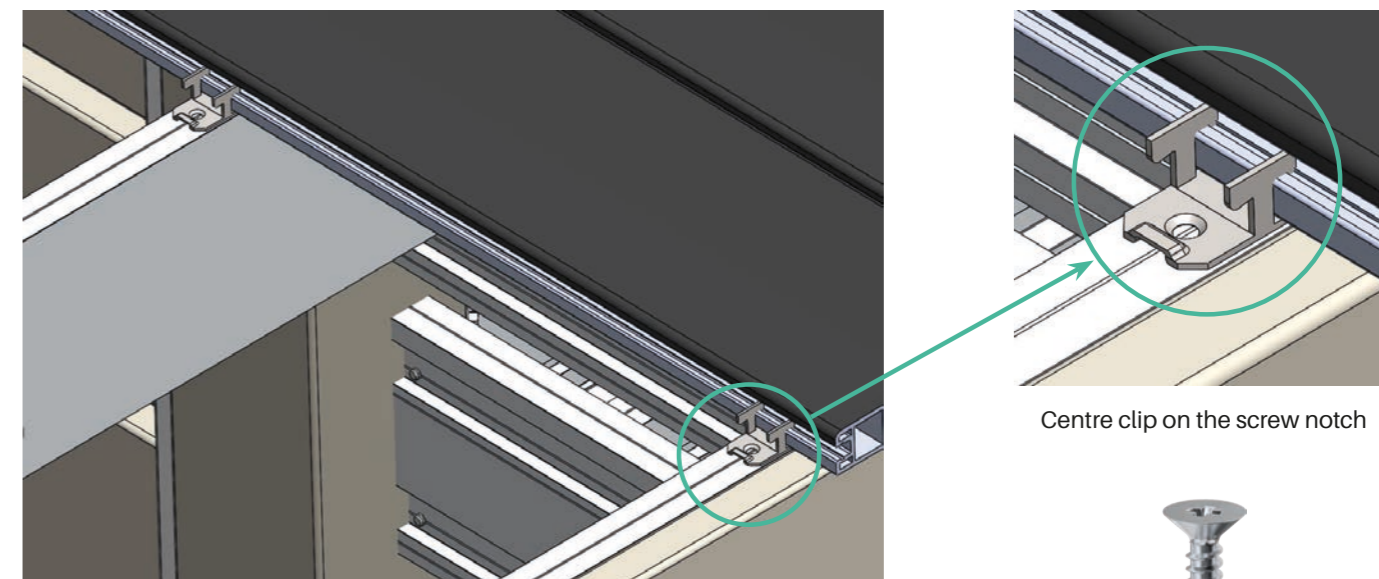

Centre clip on the screw notch



DACLIPSCREW16 Fixing

Deck Plank to Beam / Joist Install	Fixing
Clip	DTCLIP250 Deck Clip
Fixings	No.8 x 16mm Pozi self drilling, stainless steel countersunk screws. 1 per clip.
Fixing Centres	Maximum 400mm



DTCLIP250 Deck Clip

IMPORTANT!

Do NOT use impact drivers to fix the screws.

Step Installation

Steps

Steps should be constructed as a series of subframes fixed to vertical corner posts. These are essentially smaller versions of the ring beam described on page 5 - 8.

Steps should be constructed at a nominal 30° gradient using the dimensions shown below.

The number of frames required to reach the top of the subframe is shown in table A below. The position of the top of each step subframe is determined by calculation - see below.

When constructing steps, consideration must be given to the placement of any gates, windows, balustrading or other objects.

Example of a 3 Tread Step Unit

Note

Dimensions give a 10mm tread overhang

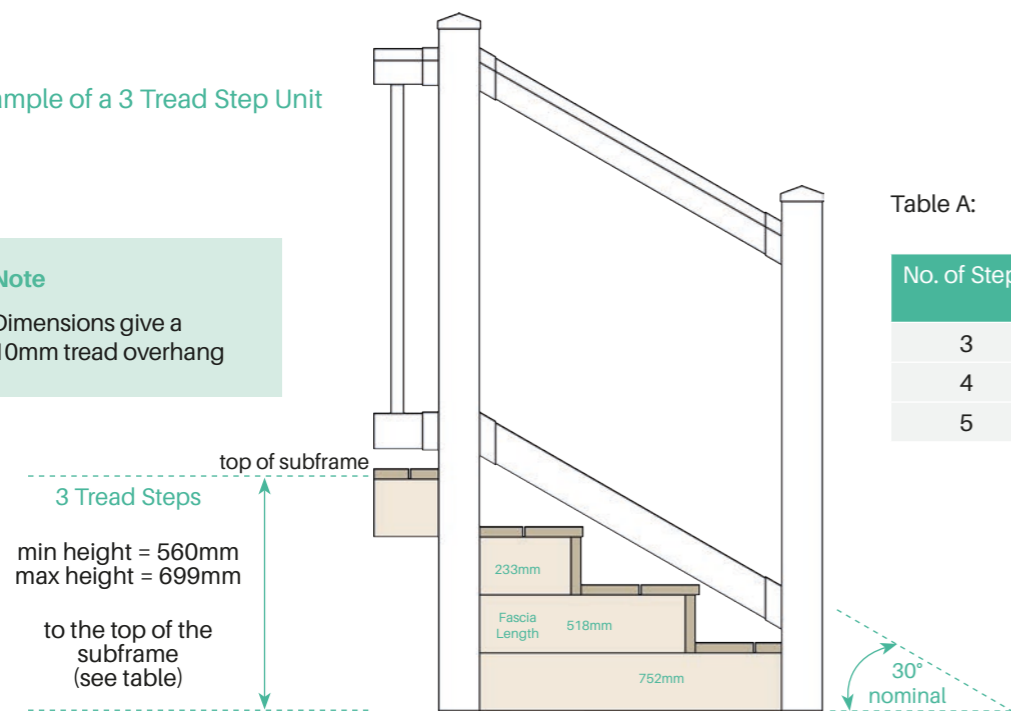
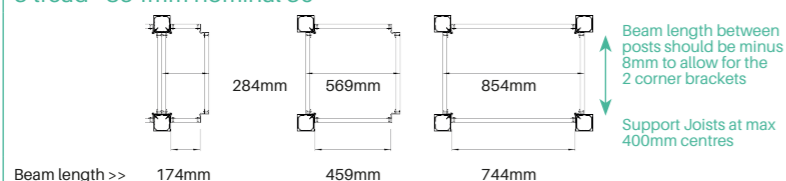

Table A:

No. of Steps	For deck height range (mm)
3	560 to 699
4	700 to 839
5	840 to 979

Dimensions for Step Subframes

3 tread - 854mm nominal 30°



4 tread - 1139mm nominal 30°

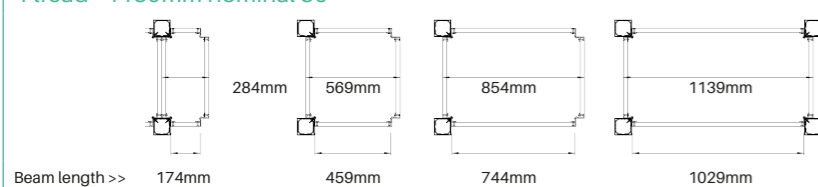

Note

Use a corner bracket to every step subframe corner.

Step Position Calculation

The position of the top of each step subframe is calculated as follows:

$$\text{Deck Subframe Height} \div \text{No. of Steps} + 1 = x$$

Mark the step posts attached to the deck subframe at "x" intervals.

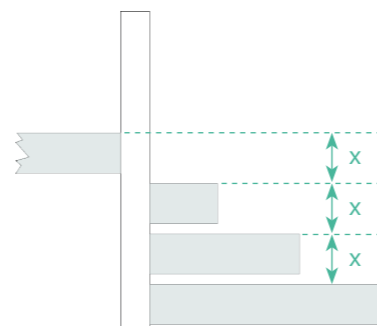

Creating Ring Beams for Steps

Step Ring Beam Construction

Drill 2 x 7mm clearance holes at each end of the beams using the drill jig provided. This ensures the holes are 12.5mm from the end of the beam. Join using 4 x corner brackets.

Beam Fixing	Fixings
Pre-Drilled Holes	2 x 7mm holes, 12.5mm from the beam end
Beam to corner bracket	2 x M6 x 25mm stainless steel socket head cap screws

Step Module Construction

Once all 4 beams are connected to the corner brackets, mark up joist centres on top of the front and rear beams at maximum 400mm centres. It is recommended that step joist centres are reduced as steps are an area of high loading.

Drill 2 x 7mm clearance holes through beams using the drill jig provided.

Insert joists into position within the ring beam, sitting the joist on the lip at the bottom of the beam.

Secure joists into position with 2 x No. 14 self-tapping 70mm zinc coated pan headed Torx screws (T30)

The self tapping screws should locate into the screw ports, provided in the joist, at each end.

Joist Install	Fixing
Centres	max 400mm centres
Pre-drilled Holes	2 x 7mm pre-drilled holes through the beam at each joist centre mark
Fixing	2 x No.14 self-tapping 70mm zinc coated pan headed Torx screws (T30).

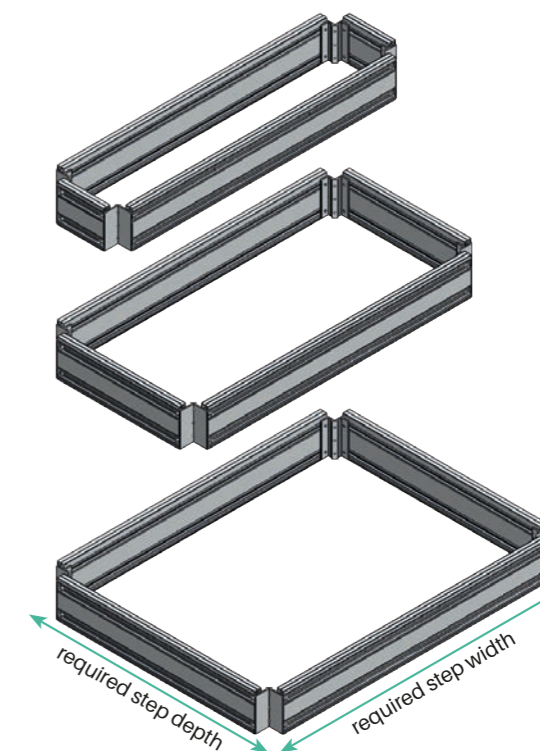
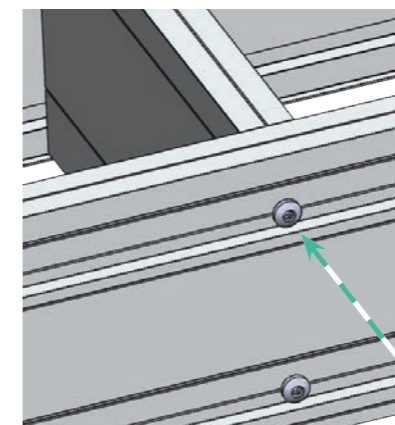

Note

Ensure beam lip is positioned to the bottom inside edge to provide support for the joists/noggins.

Step Subframe Construction

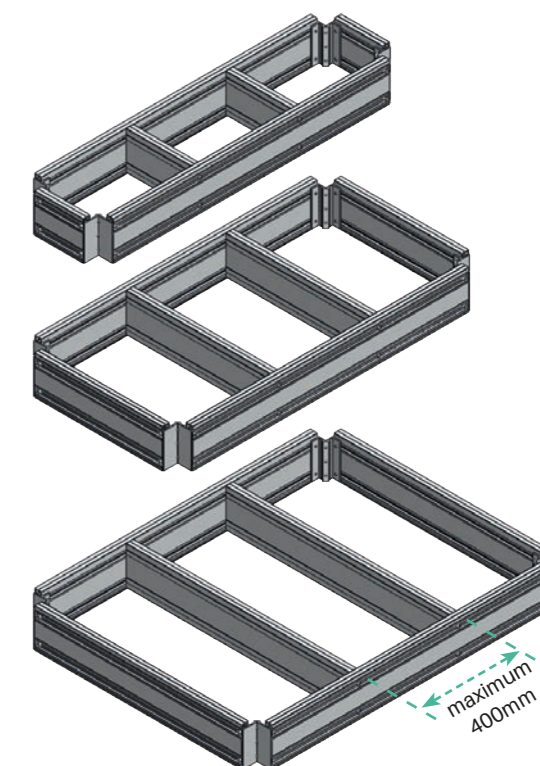

Fixing Step Subframes to Posts

Assembling the Step Subframes

Align the top of the lowest step subframe with the bottom marks on the step post (see Page 12).

Ensure the frame is level before securing the rear corner brackets to the Posts with 3 x No.12 x 50mm stainless steel self-drilling hex screws per bracket.

Tip

To prevent movement when drilling, use a quick release clamp to hold the jig in place.

Level the step subframe front to rear, prior to installing the front Posts via corner brackets and self-drilling screws.

Note

It may prove to be easier to pilot drill holes through the PVC-U, with a 5.5mm drill bit, prior to inserting the screws.

The top of the second step subframe is then aligned with the next set of marks on the step posts and secured as per the lowest step.

This should be repeated until all step subframes are installed.

Corner Bracket to Post Install	Fixing
Pilot Holes (through PVC-U)	3 x 5.5mm Pre-Drilled Holes
Fixings (per Bracket)	3 x No.12 x 50mm stainless steel self-drilling Hex screws per bracket

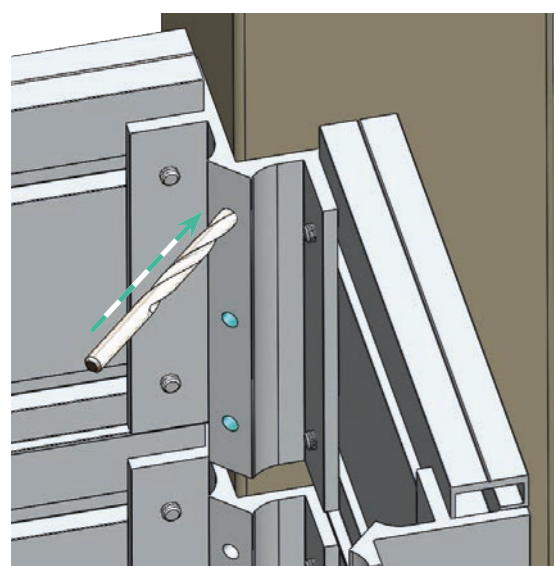
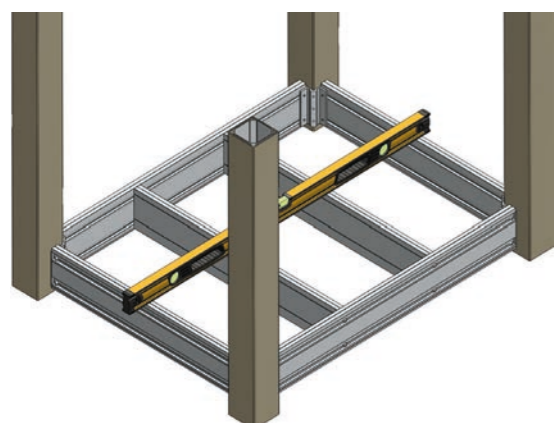
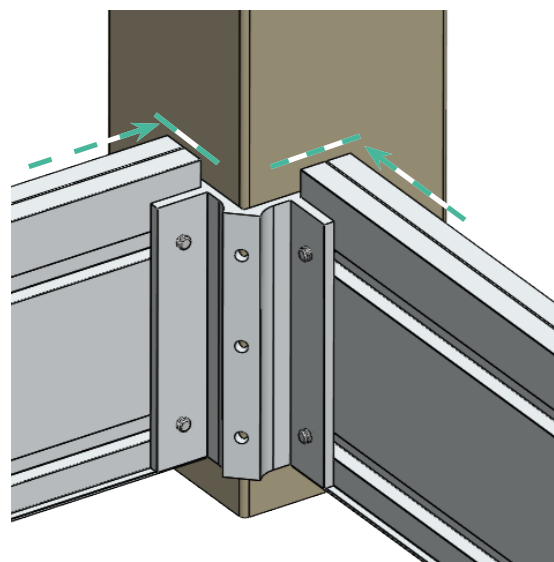

Fixing Step Subframes to Posts

Assembling the Step Subframes

Repeat the process for all the step subframes until they are all in position and level.

The front of each step subframe, not fixed to a post, should be temporarily held in position using packers / wedges where required.

Corner Bracket to Post Install	Fixing
Pilot Holes (through PVC-U)	3 x 5.5mm Pre-Drilled Holes
Fixings (per Bracket)	3 x No.12 x 50mm stainless steel self-drilling Hex screws per bracket



Important!

Do NOT use impact drivers to fix the screws.

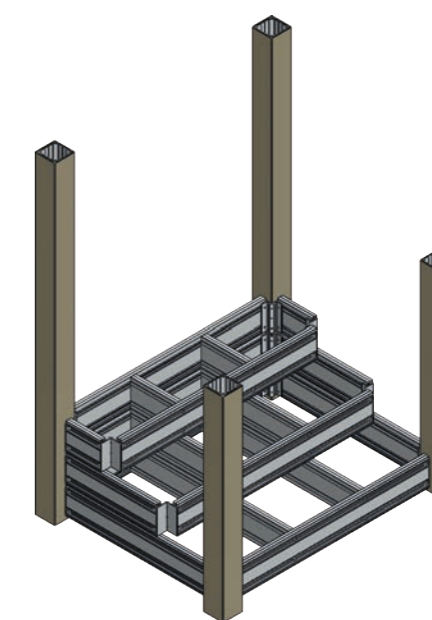
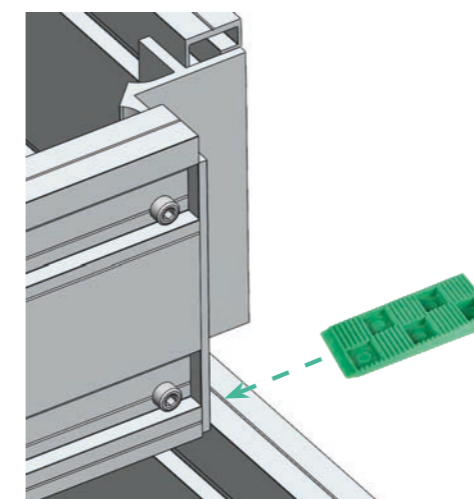
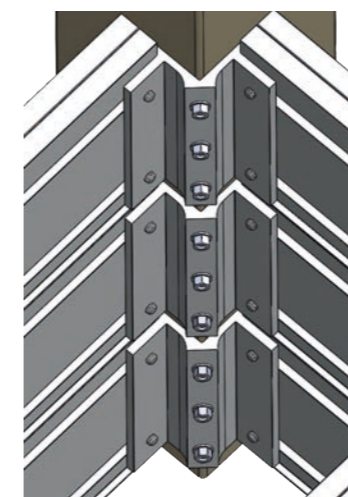
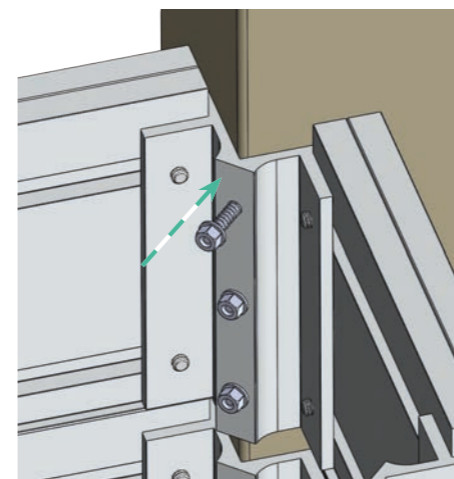

All step subframes in position

Securing the Front of Step Subframes

Attach the L Bracket to Corner Bracket

The front of the leveled step subframes are secured with L Brackets as shown in the diagram.

The brackets are firstly secured to the corner brackets with a No.12 x 50mm stainless steel self drilling hex screw. **A**

Note

It may prove to be easier to pilot drill holes with a 3.5mm drill bit.

L Bracket to corner bracket install	Fixing
Pilot Hole	1 x 3.5mm pilot drilled hole per bracket
Fixings (per Bracket)	1 x No.12 x 50mm stainless steel self-drilling Hex screw per bracket



DACBKTSREW50 Fixing

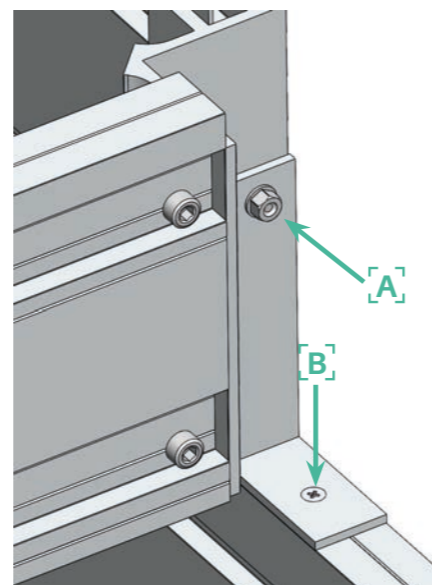

Position the L Bracket and fix through the corner bracket

Attach the L Bracket to the Top of the Beam

L Brackets are then secured to the Beam of the step subframe below using No.8 x 16mm Pozi self drilling, stainless steel countersunk screws. **B**

L Bracket to beam top install	Fixing
Fixing	1 x No.8 x 16mm Pozi self drilling, stainless steel countersunk screws



DACLIPSCREW16 Fixing

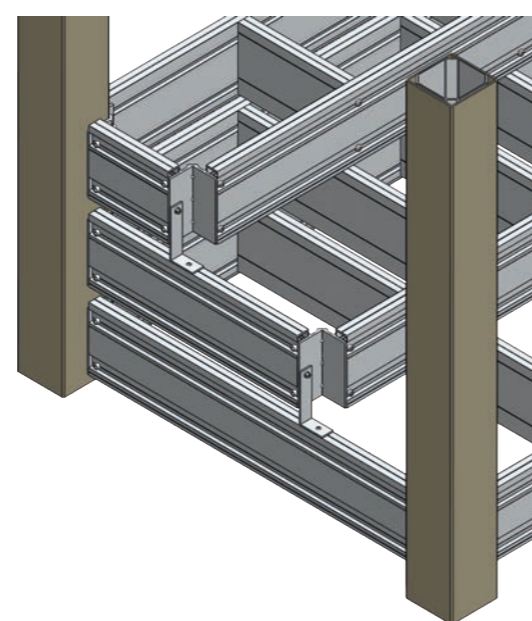

Attach the L Bracket to the top of the beam

IMPORTANT!

Do NOT use impact drivers to fix the screws.

Inbound Posts for Steps

Creating Inbound Posts

To create an inbound post, the bracket must first be re-positioned.

A bracket in the normal position is shown in Fig. A.

Rotate the bracket so it is in the same orientation as Fig. B.

Ensure the bracket is sat on the ring beam lip on the inside inner face.

Pre drill through the bracket with a 5mm drill bit Fig. C.

Tip

To prevent movement when drilling, use a quick release clamp to hold the jig in place.

Move post into position and secure with 7 x No.12 x 50mm self drilling hex screw into the post Fig. D.

Note

It may prove to be easier to pilot drill holes through the PVC-U, with a 5.5mm drill bit, prior to inserting the screws.

Corner Bracket to Post Install	Fixing
Pilot Holes (through PVC-U)	3 x 5.5mm Pre-Drilled Holes
Fixings (per Bracket)	7 x No.12 x 50mm stainless steel self-drilling Hex screws per bracket



DACBKTSREW50 Fixing

Important!

Do NOT use impact drivers to fix the screws.

Fig. A

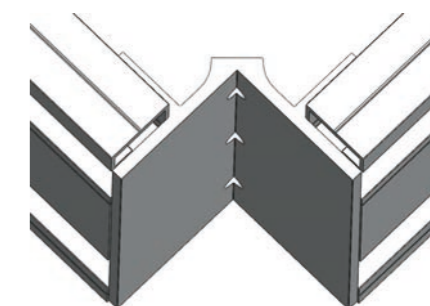

Bracket in normal position

Fig. B

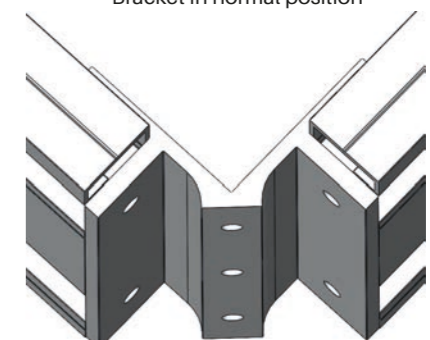

Fig. C

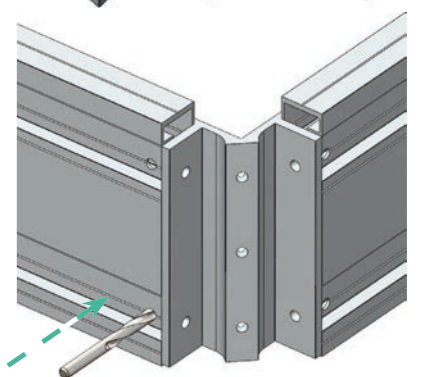
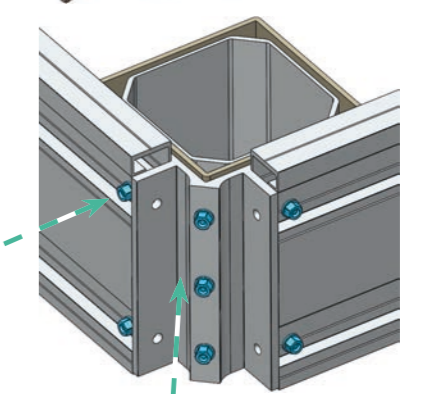

Fig. D



Step Fascia Preparation

Fascia for the Step Risers

The fascia for the first step riser (bottom step) should be cut to the distance between posts.

The fascia for subsequent step risers should be cut 45mm longer than the subframe width and positioned centrally to provide an equal overhang at each end.

Fascia for Step Sides

Plan to install the side fascia from the top down without leaving any gaps between plank edges. Any required cut to an edge is undertaken along the bottom edge of the bottom fascia.

Side Fascia boards should span the distance between rear posts and the rear face of the riser fascia or rear posts and front posts, dependant on its position in the step construction.

Note

It is important that fascia is flush with the top of the Ring Beam in areas used for DekBoard installation.

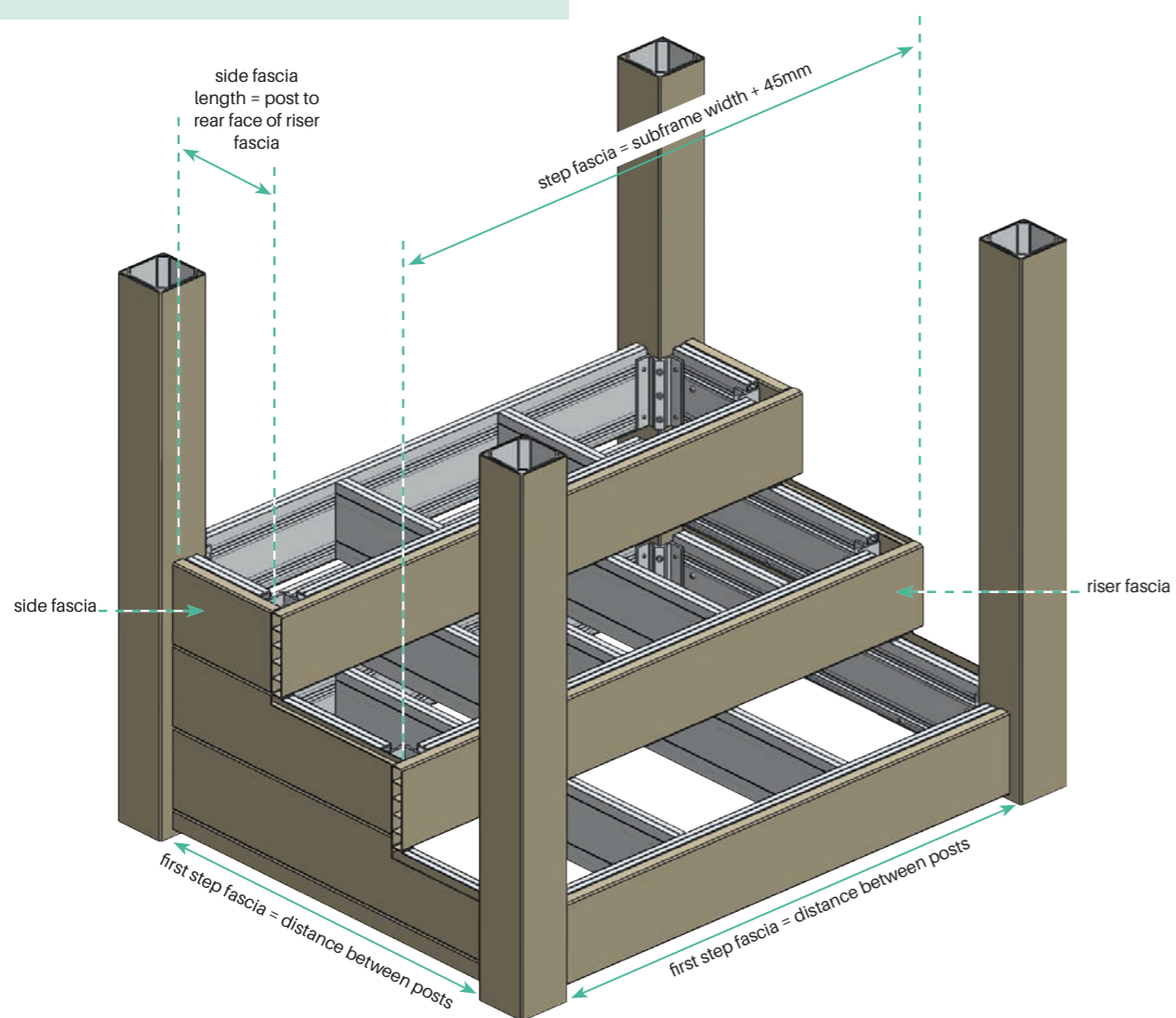

Step Fascia Fixing

Fascia Fixing

Drill clearance holes using the drill jig at the two points as shown using a 5.5mm drill bit. It is recommended to drill the beam from the outer face inwards.

Max fascia fixing centres 1200mm.

Fix fascia in place from inside face of beam using 2 x No.10 x 38mm self-tapping stainless steel pan head screws.

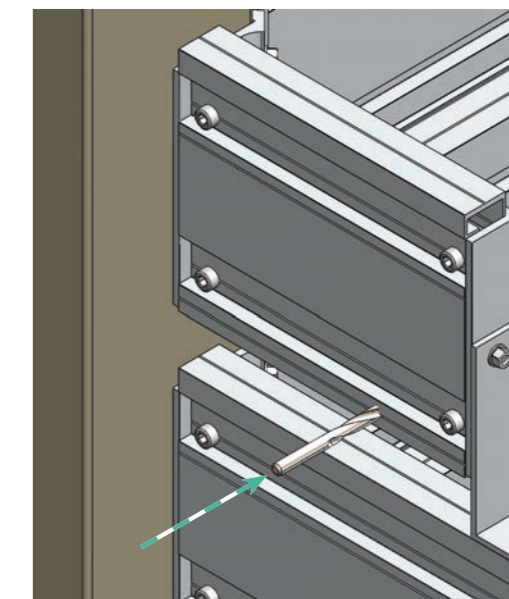
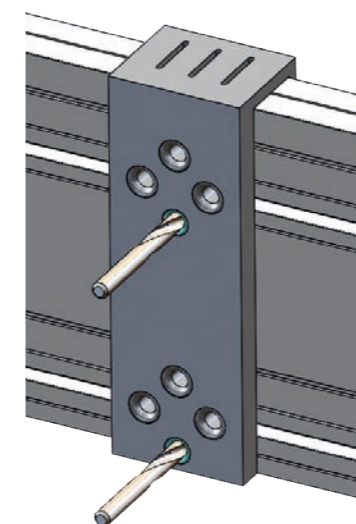

TIP

To prevent movement when drilling, use a quick release clamp to hold the jig in place.

Fascia to Beam Install	Fixing
Pre-drilled Holes	2 x 5.5mm pre-drilled holes (from the outside)
Fixings	2 x No.10 x 38mm self-tapping stainless steel pan head screws (from the inside)
Fixing Centres	Maximum 1200mm



DAFASCIASCREW38 Fixing

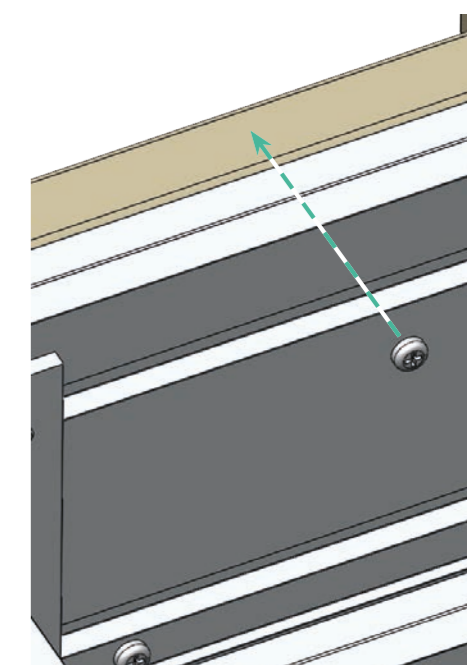

Fix through the beam into the rear of the fascia

Fascia Finishing Trims

Finishing the Fascia at Exposed Corners

The fascia to the first step finishes at the post so has no requirement for a corner joint.

The corner of subsequent step fascias should be finished as per the diagram.

Use the matching colour DekBoard angle trim and cut to size.

Fix with a low modulus silicone to both faces.

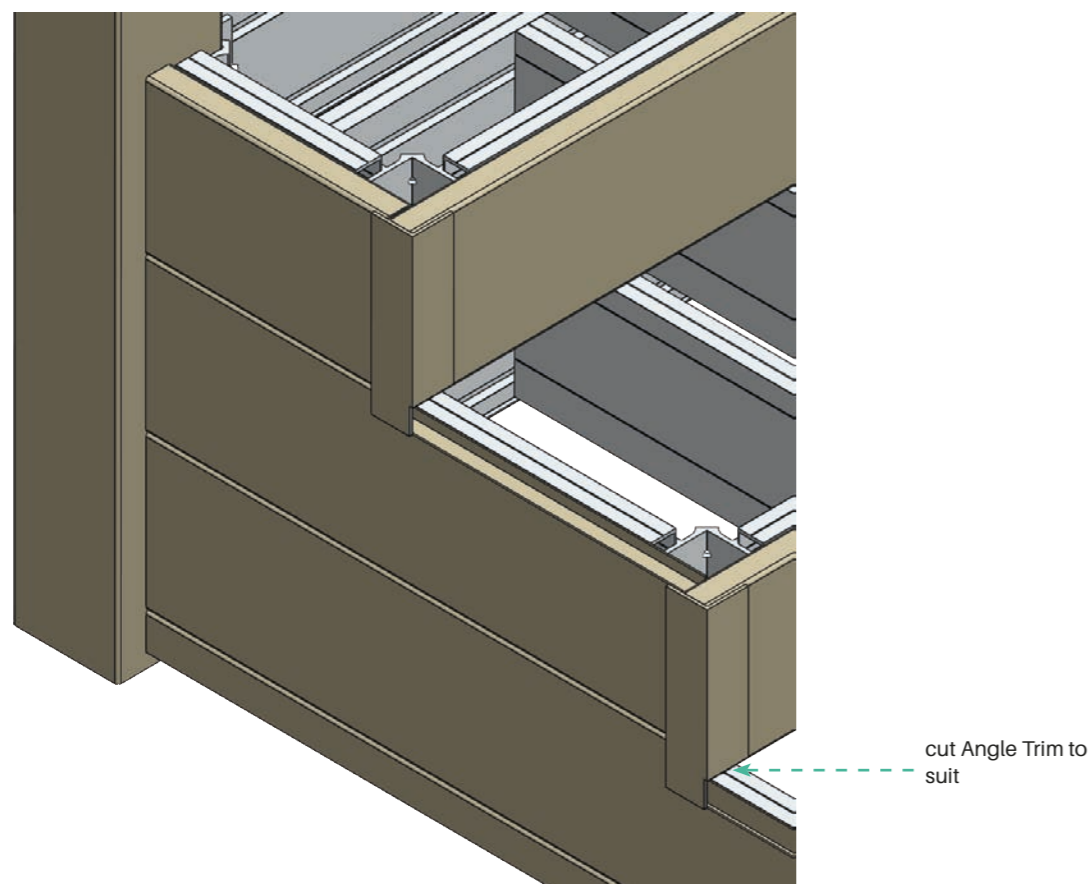

Angle Trim to Fascia fix	Fixing
Corner trim	Low modulus silicone to ISO 11600-F&G-25LM

Note

Do NOT use cyanoacrylate adhesive (Superglue) on foiled products

Fixing Deck Planks to Steps

Screw Fixing

Drill pilot holes, as required, for each fixing centre using a 3.5mm drill bit. It is recommended the holes are a minimum 20mm in from the deck plank edges.

Secure decking planks to the subframe using No.8, 4.2mm x 38mm, stainless steel, self tapping flanged button screws.

Clip Fixing

Secure centre of the decking planks to the subframe using decking clips with No.8 x 16mm Pozi self drilling, stainless steel countersunk screws.

Add infill trim to the leading edge plank and edge trim to the sides to complete the installation.

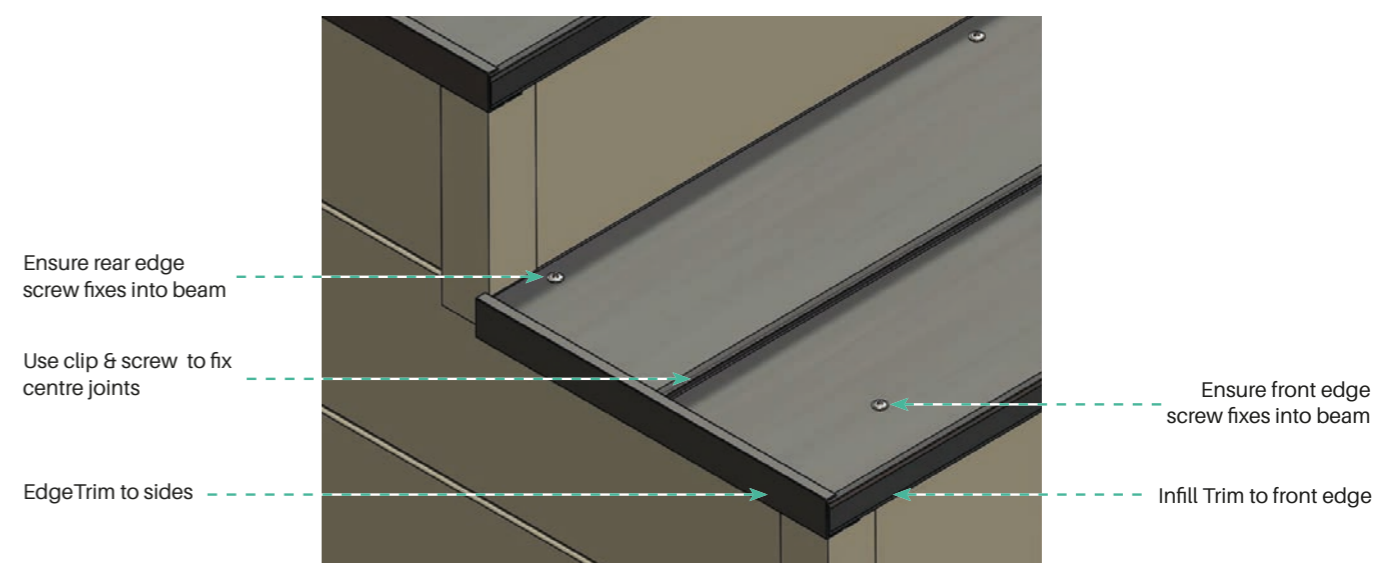

Note

Ensure the front screw to the leading edge fixes into the beam

Deck Plank to Beam / Joist Install	Screw Fixing
Pre-drilled Holes	3.5mm pre-drilled pilot holes
Fixings	No.8 x 38mm Pozi Self Tapping Flanged Button Screw 2 per fixing centre.
Fixing Centres	Maximum 400mm
Deck Plank to Beam / Joist Install	Clip Fixing
Clip	DTCLIP250 Deck Clip
Fixings	No.8 x 16mm Pozi self drilling, stainless steel countersunk screws. 1 per clip.
Fixing Centres	Maximum 400mm



DASTEPCREW38 Fixing



DACLIPSCREW16 Fixing



DTCLIP250 Deck Clip

Post Light Fixing

Installation

The Post Sleeve top must be cut square and level to ensure a solid base for the light assembly.

Position of Lighting Cable

Aluminium Post Run the cable inside the aluminium post.

Important!

Consideration must be given to the position of the cable with regard to any fixing screws (Fig.A)

Cabling for the Lights

Run the cable in a loop up and down each post, ready for the electrician to terminate (Fig. B).

This will enable a loop from one light to the next via the wagos installed inside the light fixture.

Note

Recommended cable: 1mm², 2 Core to H07RN-F.

Allowances for the LED Light Assembly

The aluminium post should be cut 35mm shorter than the post sleeve to allow for the light assembly hardware (Fig. C).

The PVC-U post sleeve should be cut 36mm shorter than a standard post so all post caps are at the same height.

LED Driver Specification

The lights all run on 12v DC which will require a 2 core cable running to each light.

To convert the 240V down to 12V, an LED driver, will be required. This should be installed at the start of the lighting project and protected from the elements.

Each light fixture requires approximately 5 watts from the LED driver. For every additional lamp installed an additional 5 watts of output will be needed.

Example:

To install 12 lights, a driver with an output of 60W will be required - (Fig. D).

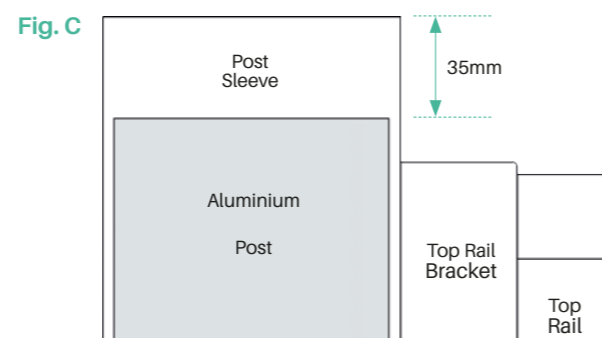
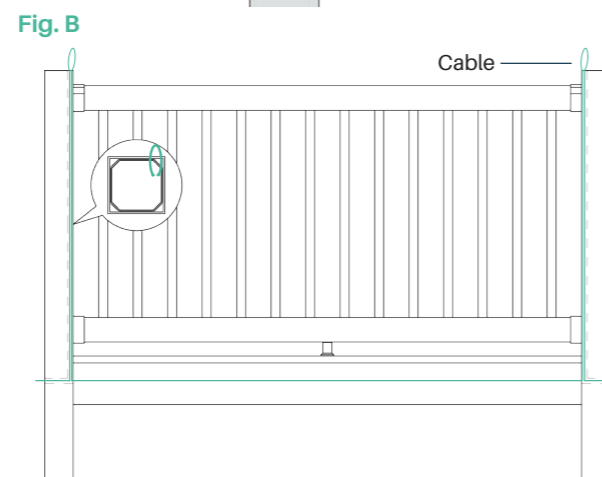
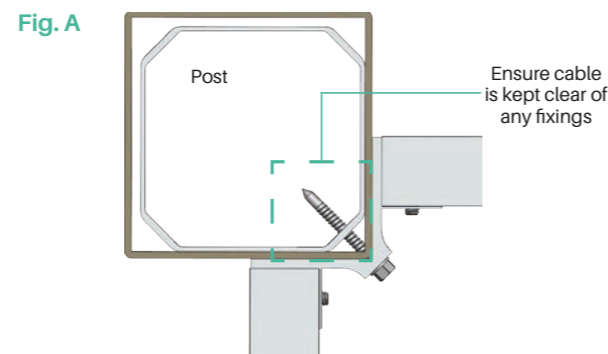

Note

The LED driver should be located / installed where it will be protected from the elements.

Important!

It is recommended that a qualified electrician carries out connection of ALL wiring

Post Light Fixing

LED Light Fitting Installation

The aluminium post should be cut 35mm short of the post sleeve to allow for the light assembly hardware (Fig. A & B).

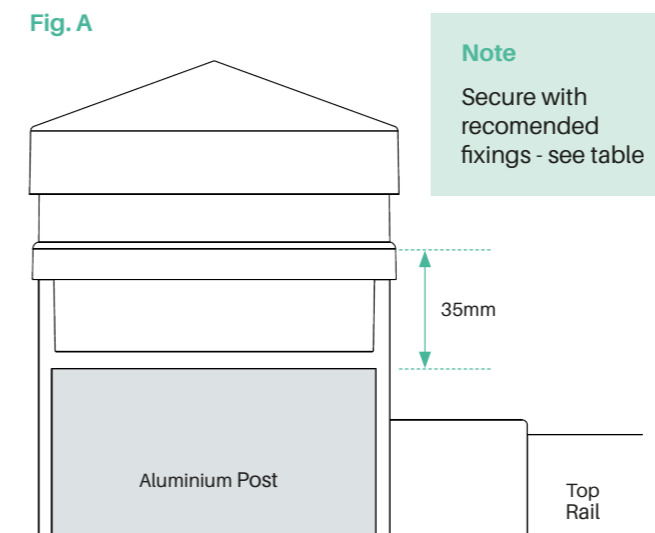

LED Light Fitting	Fixing
Fix Post Cap to LED Light assembly	Low modulus silicone to ISO 11600-F&G-25LM

Globe & Lantern Light Fixing

Globes and Lanterns should be fixed to a full height post (Fig. C).

The Post Sleeve top must be cut square and level to ensure a solid base for the light assembly.

Use suitable stainless steel or colour matched screws to secure the light fitting to the post.

LED Light Fitting	Fixing
Pre-drilled Holes for an Aluminium post	4 x 3mm pre-drilled holes through the post
Fixing light fitting to the post	Suitable Stainless Steel or colour matched screws

Fixing LED Light to an Aluminium Post

Drill 2 x 3mm pilot holes through the post sleeve & LED assembly base, approx. 20mm from the top of the post sleeve (Fig. B).

Fix through the pre-drilled holes into the LED assembly to secure.

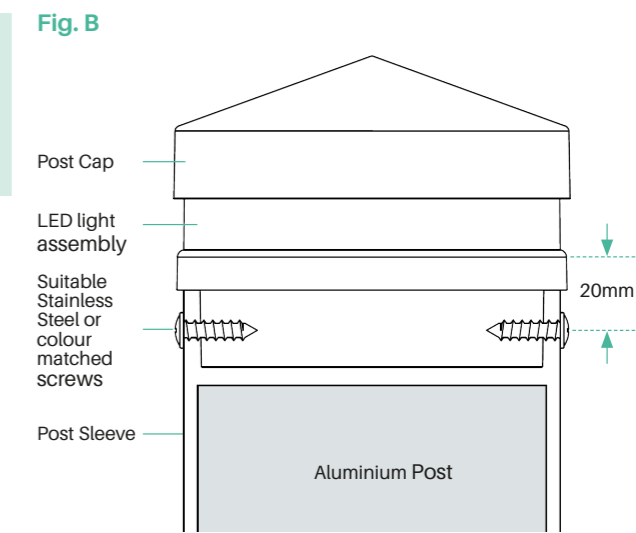

LED Light Fitting	Fixing
Pre-drilled Holes for an Aluminium post	2 x 3mm pre-drilled holes through the post sleeve & LED assembly base
Fix LED light assembly to an Aluminium post	Use 2 x 16mm Stainless steel Pozzi panheaded screws (Fig. B).

Fig. C

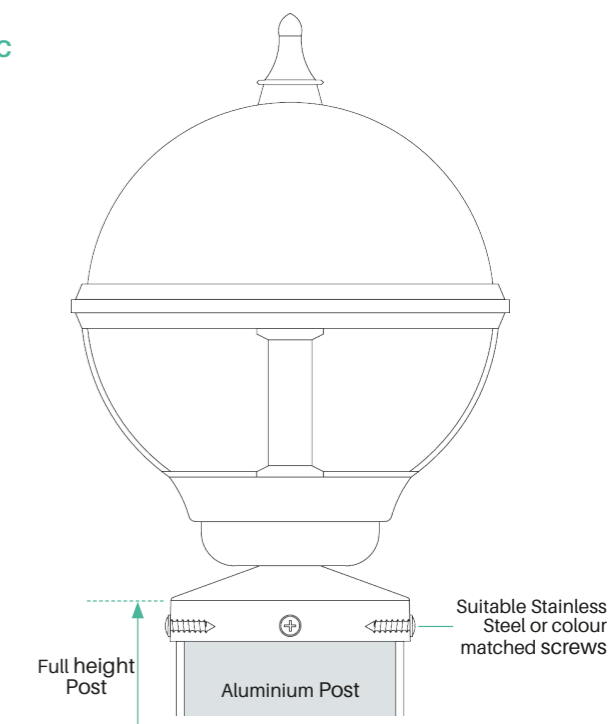

Gate Hanging

Fixing Gate to the Post

A standard gate for an aluminium subframe is 960mm wide by 850mm high. The hinges and latch / lock assembly require a minimum 24mm (nominal 25mm) clearance each. Gate posts should therefore be installed 1010mm apart.

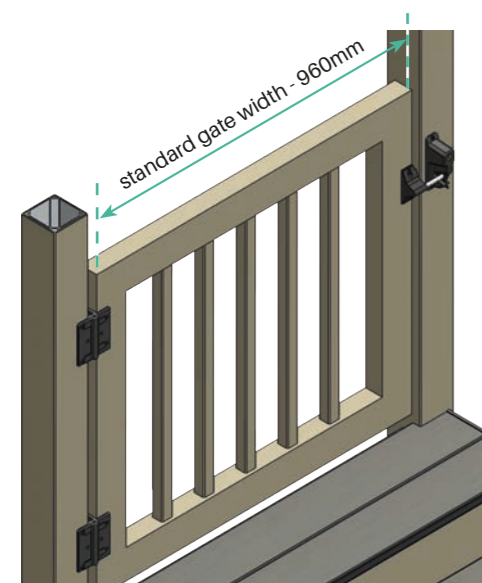

Important !

Only use the fixings provided with the latch & lock.

TIP

Care should be taken to select the correct screws - See fixings table below.

Note

Aluminium subframes require a different latch / lock assembly from our standard range.

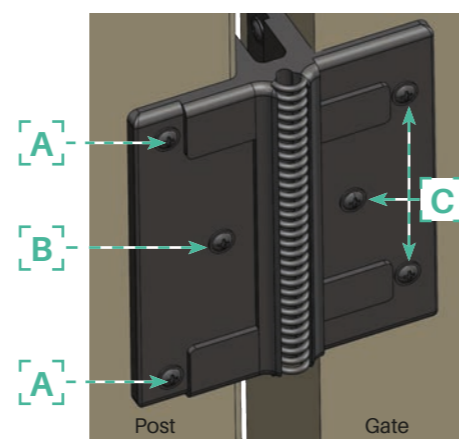

Fix DALHINGE to gate / post

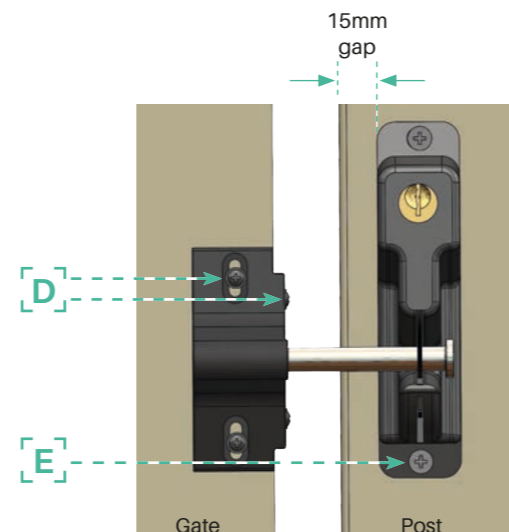
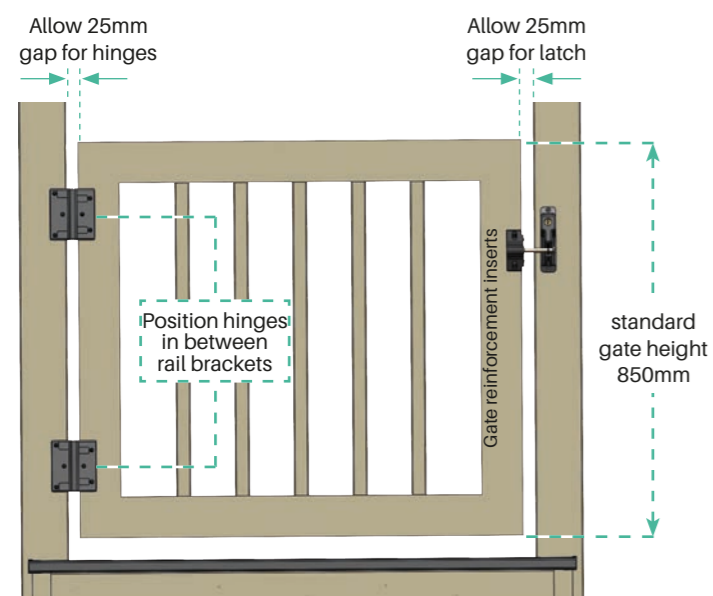

Fix DALLATCH assembly to gate / post

Gate to Post fix	Type	Quantity	Fixing
Hinge Fix	A	x 4 per hinge	No.8 (4.2mm) x 25mm pozi self tapping flanged button screws black stainless Steel A2
	B	x 2 per hinge	No.8 (4.2mm) x 13mm pozi self tapping flanged button screws black stainless steel A2
	C	x 6 per hinge	No.9 (4.5mm) x 40mm flange head black wood screws
Latch Fix	D	x 4 per latch	No.8 x 19mm pozi pan head black wood screws
Latch Lock Fix	E	x 2 per lock	No.8 (4.2mm) x 25mm countersunk self tapping screws black stainless steel A2

Fixing Summary

The following tables are a summary of full fixing instructions which are covered previously in this guide. Please refer to the full section for more details





Groundworks / Preparation Details		
Deck Plan	Detailed Plan	It is important to pre-plan the deck area. Plan the deck to make best possible use of materials.
Foundations	Posts / intermediate supports	Posts should be set onto a solid and level surface. Checks should be undertaken to ensure ground stability.
Ground membrane	Weed Control	To be positioned at ground level as required.
Ventilation		
Ventilation to subframe / deck area	To reduce heat build-up	It is essential that a minimum 10mm continuous ventilation gap is provided underneath the base of the deck, providing thorough ventilation. Using recommended beams / joists, air gap and DekBoard will result in a minimum deck surface height of 185mm.
Subframe - Construction Details		
Subframe construction	Joining	When required, adjacent subframe modules can be connected using a stainless steel socket headed screw, nut and washer.
	Support	Subframes MUST be supported at maximum 2.22m spans.
	Joist Spacing	Deck joists should not exceed 400mm (16") centres, with reduced centres recommended in high foot traffic areas.
	Joist Noggins	Maximum 1.11m span between noggin centres.
Subframe Bracket fixings	1 per subframe corner	Use 3 x 50mm hex screws per bracket, 2 x M6 25mm cap screws per beam.
Deck Construction Details - Posts		
Posts	Placement	Posts are required at every subframe module corner.
Posts- Intermediate	Placement	Subframes MUST be supported at maximum 2.22m spans.
Posts	Height	Standard post heights are set 995mm from the top of the subframe.
Post Electrical Cabling	Placement	Consideration must be given to the position of the cable with regard to fixing screws.

Summary of Terminology and Key Dimensions

Terminology	Description
Subframe	The complete structure onto which the decking planks are secured.
Subframe Module	Ring beam, Joist / Noggin assembly secured together to form the subframe.
Ring Beam	The beam and corner bracket assembly.
Joist Centres	The distance between joists measured at the joist centre line.
Post Assembly	PVC-U Post Sleeve with full height Post Insert.
Key Dimensions	
Post Spacing	The maximum distance between posts is 2220mm.
Beam Length	The distance between the posts - 8mm. (8mm is the allowance for 2 x corner brackets.)
Beam Centres	The distance between the posts + 76.5mm.
Joist Length	The distance between the posts + 52mm (51.6mm actual).
Joist centres	Max 400mm. To calculate beam centres: Beam centres ÷ No. of Joist + 1.
	Example: 1800mm requires 4 joists (5 gaps) at 360mm centres.

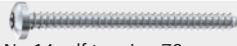
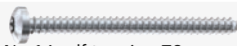
Technical Information

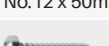
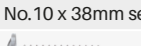
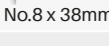
Fixings Summary

Fixing	Code	Unit	Application	Notes
 No.14 self-tapping 70mm panhead Torx screw	DAJOISTSCREW70	Box	Fix Beam to Joist / Noggin	Zinc Plated- clearance hole required
 No.14 self-tapping 70mm panhead Torx screw	DANOINSCREW70	Box	Fix Noggin to Joist	A2 Stainless steel- clearance hole required
 M6 x 25mm socket head cap screw	DABEAMSCREW25	Box	Fix Beam to Corner Bracket	A2 Stainless steel- clearance hole required
 No.12 x 50mm self-drilling hex screw	DACBKTSREW50	Box	Fix Corner Bracket to Post Fix Step Bracket to Corner Bracket	A2 Stainless steel- clearance hole recommended
 No.10 x 38mm self-tapping, pan head screw	DAFASCIASCREW38	Box	Fix Fascia to Beam	A2 Stainless steel- clearance hole required
 No.8 x 38mm Pozi Self Tapping Flanged Button Screw	DASTEPCREW38	Box	Fix Decking to Step Beam / Joist	A2 Stainless steel- pilot hole required
 No.8 x 16mm Pozi self drilling, countersunk screw	DACLIPSCREW16	Box	Fix Deck Clip to Beam / Joist Fix Step Bracket to Beam / Joist	A2 Stainless steel
 No.8 x 25mm Pozi self drilling, countersunk screw	DARBKTSREW25	Box	Fix Rail Bracket to Post	A2 Stainless steel

Load Span

All DekBoard® decking products have been load tested.

DekBoard® point loads tested at different spans.

Table 1 shows point loads against spans to ensure you can choose the correct bearer spacing to ensure you comply with 'BS EN 1991-1-1:2002 Actions on structures - Imposed loads for buildings'.

Table.1	DekBoard		
SPAN (mm)	300	350	400
Max point load (kN) *	5.0	4.2	3.6

Load Test Report

DekBoard has carried out in-house testing to demonstrate the high strength and performance of the aluminium subframe and PVC-U decking system.

A deck was constructed with a maximum 2.22m between posts without additional support. The deck was then tested with the required load. Results are shown in the table below.

Load kN/m ²	Time under Load	Performance	Reference
1.5	1 hour	Did not fail	BS 6399 : Part1 : 1996 COP for dead & imposed loads
2.5	1 hour	Did not fail	BS EN 1991-1-1-2002 Actions on Structures
3.0	19 hours	Did not fail	Timber Decking Association – raised decks

DekBoard Aluminium Subframe 10 Year Product Guarantee

The guarantee covers DekBoard Aluminium Subframe products (the Products) used on the installation. This document is not an installation guarantee and therefore does not cover any aspect of the installation of the Products.

The Manufacturer guarantees the Products from the date of installation subject to the Terms and Conditions.

Terms and Conditions

- The Guarantee Period shall be 10 years from the date of installation.
 - The Guarantee only applies where product defects appear within the Guarantee Period and is reported in writing within 14 days. Claims should consist of a full description of the fault and photographic evidence.
 - The sole and exclusive remedy with regard to the Guarantee is limited to the repair or supply of replacement product at the Manufacturer's discretion, after consultation and agreement with the Installer. The Manufacturer does not make any other representation or guarantee and in no event shall the Manufacturer be liable for any other loss or damage whether direct or indirect (including but not limited to the cost of installation).
 - The Products are guaranteed for use in the Holiday / Leisure Home and Residential Park Home market for a period of 10 years from the date of installation, not to suffer from structural failure below a design load of 2.5kN/m², provided that the decking surface is no greater than 2m above the lowest point of supporting ground. Products must have been installed by the Installer in accordance with the Dekboard Installation Instructions and have been subjected to normal use and service conditions. (Design Load based on BS EN 1991-1-1-2002 Areas for domestic and residential activities - Balconies in single family dwelling units).
 - No further guarantees are offered on durability, impact resistance, colour change, abrasion resistance, stain resistance, resistance to scratching or performance under abnormal weather conditions, fair wear and tear, aggressive industrial conditions, inappropriate applications or malicious/accidental damage.
 - The Guarantee is limited to end use of the Products in Northern Europe (latitude 45° to 60°).
 - The Guarantee does not cover any movement, distortion, collapse or settling to the ground or supporting structure on which the products are installed and which may cause damage to the product.
 - The Guarantee does not cover the Products for commercial applications.
- The following conditions will be precedent to any liability hereunder:
- Full payment for the Installation covered by this guarantee.
 - The Manufacturer's recommended maintenance procedures being followed or in the absence of such recommendations, normal and reasonable maintenance being undertaken.
 - The Products have not been coated or had any other process or repair performed on them.
 - The defect is not caused by wilful or accidental damage, vandalism or negligence.
 - The Products have not been exposed to atmospheric pollution, acid rain, harmful chemicals or vapours, fire, lightning, flood, abnormal winds or earthquake, or the effects of external heat sources or reflective surfaces, or undue wear and tear, or other unusual conditions.
 - The Products have not been moved from the site where the defect is alleged to have occurred.

Your rights:

If there is any dispute over a claim, the decision of the Manufacturer is final and binding. In addition to the foregoing the Manufacturer's standard terms of business shall apply.

This Guarantee shall be construed and interpreted in accordance with English law and shall be subject to the jurisdiction of English courts only.

The Guarantee does not affect the statutory rights of consumers.

May 2024

Billet Lane
Normanby Enterprise Park
Normanby Road
Scunthorpe
North Lincolnshire
DN15 9YH

01724 848 500

sales@dekboard.co.uk

01724 848500 | sales@dekboard.co.uk

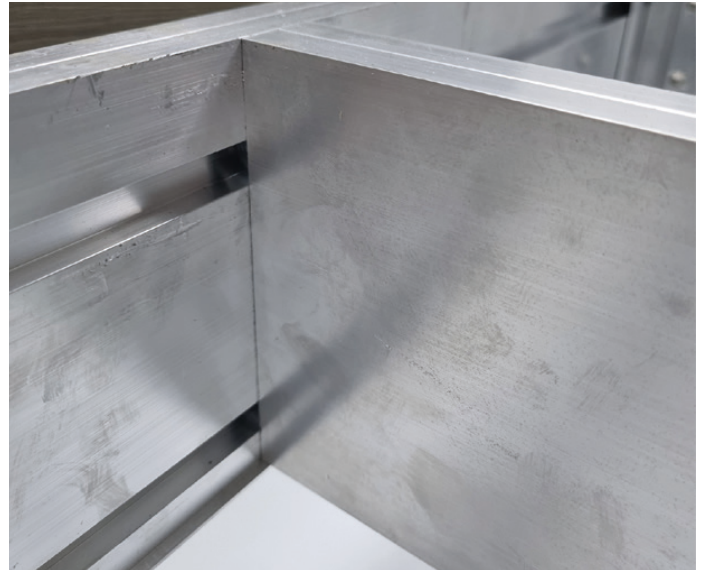
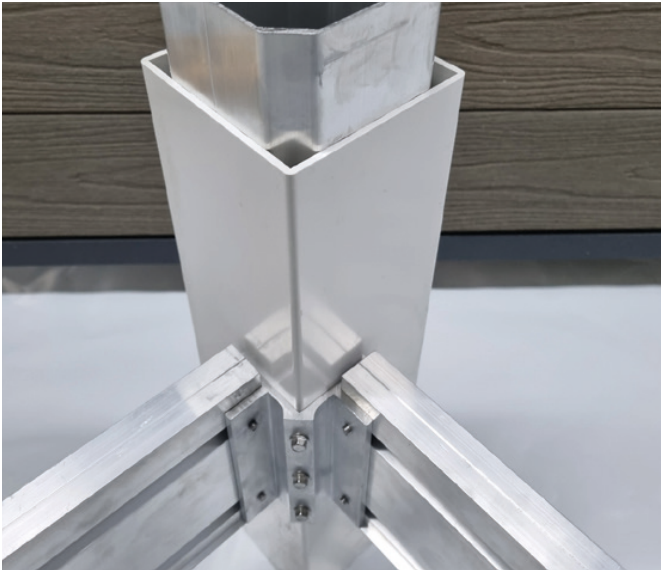

Guarantee - 10 Year Structural Performance

The Dekboard Aluminium Subframe System is guaranteed for use in the Holiday / Leisure Home and Residential Park Home market for a period of 10 years from the date of installation, not to suffer from structural failure below a design load of 2.5kN/m², provided that the decking surface is no greater than 2m above the lowest point of supporting ground. Products must have been installed in accordance with the Dekboard Installation Instructions and have been subjected to normal use and service conditions.

(Design Load based on BS EN 1991-1-1-2002 Areas for domestic and residential activities - Balconies in single family dwelling units).

See guarantee inside for complete wording.

About DekBoard

DekBoard are part of Specialist Building Products Ltd, owned by Epwin Group PLC. We have 40 years' manufacturing experience across 3 factories, and 20 years' experience in the manufacture of PVC and composite decking.

DEKBOARD

Billet Lane
Normanby Enterprise Park
Normanby Road
Scunthorpe
North Lincolnshire
DN15 9YH

01724 848 500
sales@dekboard.co.uk

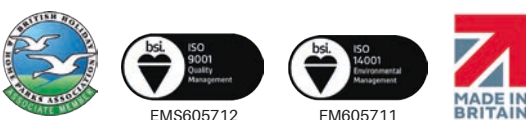

dekboard.co.uk

